

- 8", 10", and 12" diameter incline tubes.
- Electric or Hydraulic Drive.

Truck Hoppers fill elevator legs, portable augers, silage blowers, etc. from gravity wagons or grain trucks. Tube lengths are 6 or 8 ft. with custom lengths on request. 8" and 10" models have a screen tube option.

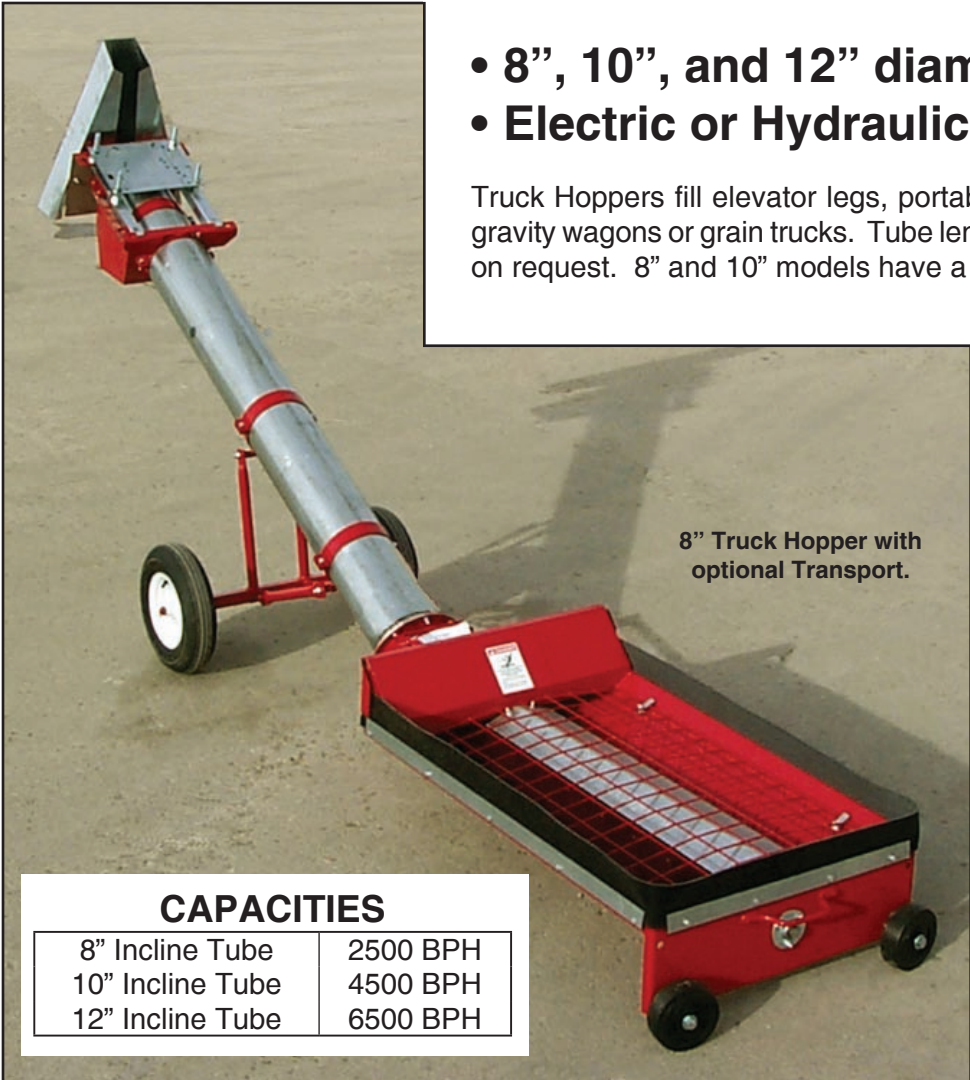

8" Truck Hopper with optional Transport.



Leg Adaptor

### CAPACITIES

8" Incline Tube	2500 BPH
10" Incline Tube	4500 BPH
12" Incline Tube	6500 BPH



10" Truck Hopper with optional Transport.

# Truck Hopper Augers

## SPECIFICATIONS

- HOPPER** . . . . . 14 ga. construction; splash guard on intake; access to U-joint on hopper-to-incline fighting connection; flexible rubber belting; rubber end wheels; safety screen over hopper fighting. 7 1/4" fighting (8" incline tube), 9 1/4" fighting (10" incline tube), and 11 1/4" fighting (12" incline tube). 10" hoppers have reduced pitch fighting.
- INCLINE AUGER** . . . 14 ga. (8" dia.) or 12 ga. (10"/12" dia.) cold drawn welded tube; 7 1/4" fighting (8" tube), 9 1/4" fighting (10" tube), 11 1/4" fighting (12" tube).
- FLIGHTINGS** . . . . . 3/16" on 1 1/2" pipe (7 1/4" fighting), 3/16" on 2 1/2" pipe (9 1/4" fighting), 1/4" on 2-7/8" pipe (11 1/4" fighting). Hopper flightings are 5/16" thick on all sizes.

## POWER REQUIREMENTS

	8" Tube	10" Tube	12" Tube
Electric Drive	2 HP	3 HP	5 HP
Hydraulic Drive	"H" Series	"H" Series	"H" Series

Electric motor horsepowers are for dry grain only. Use the next size larger motor for wet grain.

Length from horizontal-to-incline junction to end of incline tube.

## DIMENSIONS

INCLINE TUBE	A	B	C	D
8" x 6 ft.	8'-8"	27 1/2"	10 1/2"	28"
8" x 8 ft.	10 1/2'	37 1/2"	10 1/2"	28"
10" x 6 ft.	8'-8"	27 1/2"	12 1/2"	32"
10" x 8 ft.	10 1/2'	37 1/2"	12 1/2"	32"
12" x 8 ft.	10 1/2'	37 1/2"	12 1/2"	32"

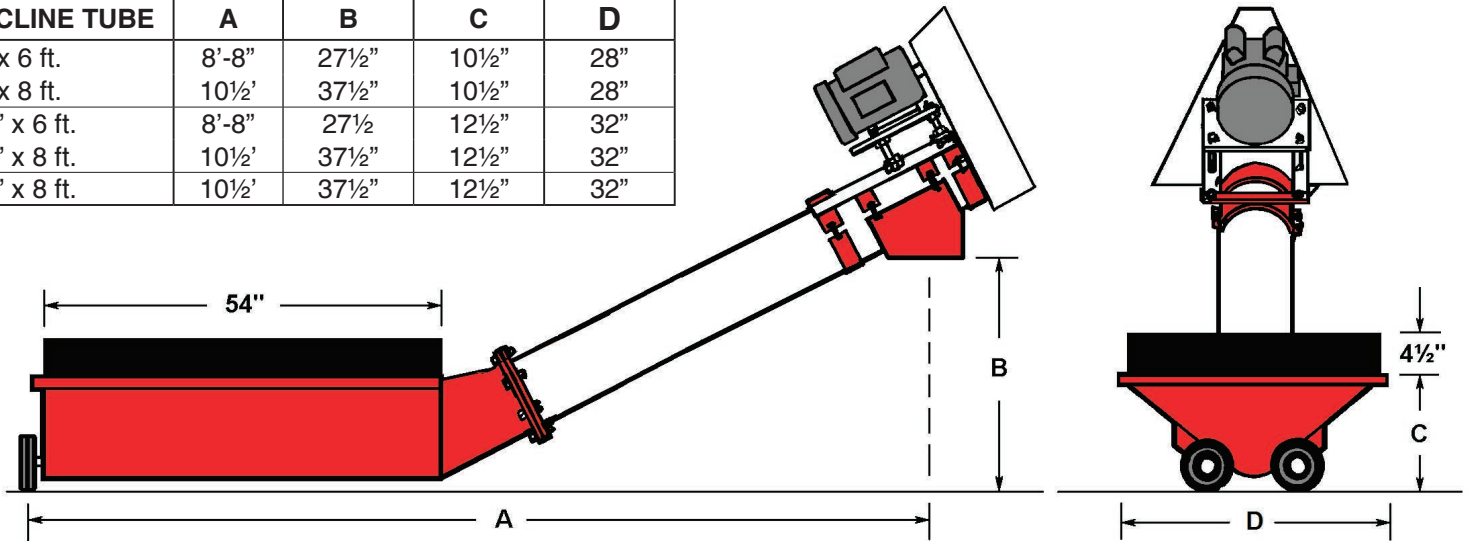

## OPTIONS

- Transport** . . . . . Tube mounted undercarriage that makes moving the Hopper easy. Includes two 4:00 x 8:00 tubeless tires.
- Swivel Wheel Adaptors** . . . Allows fixed end wheels to swivel 360°. Easy Hopper positioning.
- Leg Adaptor** . . . . . For attaching Hopper discharge to Elevator Leg intake. Eliminates moisture problems associated with dump pits.

Distributed By:

# SUDENGA INDUSTRIES, INC.

Box 8 • 2002 Kingbird Ave. • George, IA 51237 USA  
1-888-SUDENGA (783-3642) • 1-712-475-3301 • Fax: 1-712-475-3320