

- 8", 10", and 12" Auger Diameters
- 57 through 82 ft. Lengths
- Painted or Galvanized Tubes*

12" Augers now
available in 92 - 122 ft.
lengths.

MADE IN
USA

AUGER CAPACITIES

8" Dia.	up to 3200 BPH
10" Dia.	up to 5000 BPH
12" Dia.	up to 7000 BPH

Hydraulic scissors
hoist is standard.

Swing-around
Hopper available with
hydraulic positioning.

*12" augers are painted only.

Hi-Efficiency Portable Augers

SPECIFICATIONS

	8"	10"	12"
Tube Lengths	57', 61', 65', 71'	61', 66', 71', 76', 82'	61', 72', 82'
Tube Gauge	14	12	12
Tube Finish	painted or galvanized		painted
Flighting	3/16"	3/16"	1/4"
Driveline	Direct constant velocity joint on PTO-to-flighting connection; double bearings; shear pin protection.		
Transport	Hydraulic scissors lift; reinforced arms on 12", 4-bolt rims (8" augers) or 6-bolt rims (10"/12" augers), roller bearings for road transport. Transport widths - 10 ft. (8" augers) and 10.5 ft. (10"/12" augers).		
Swing Hopper	Mechanically driven by roller chain & double gearbox from auger flight, gimbal mount is easy to position, UHMW sealed hopper joint* keeps weather out and grain in. 10" and 12" hoppers are hinged at the hopper-to-incline joint. Hopper intake flighting is 5/16" thick on all models.		

Gimbal mount Mechanical Hopper

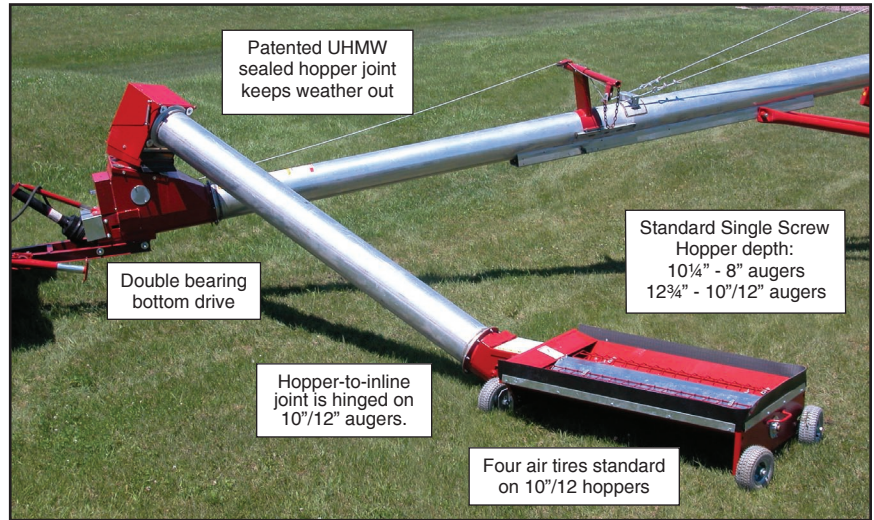

Optional Twin Screw Hopper



Left and righthand hopper flights for maximum capacity and even feeding.

Incline tube head opens fully for easy maintenance.



Easy access to grease fittings.



REACH & ELEVATION

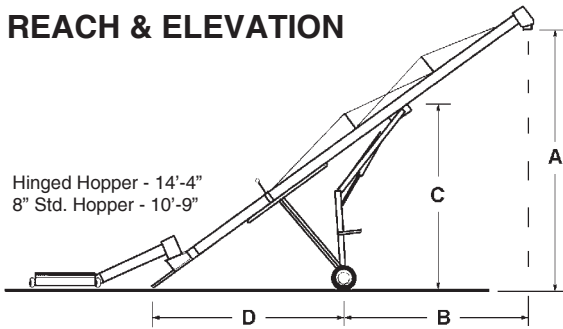

Augers at 40°	57'	61'	65'	71'	76'	82'
A - Elevation	39'	42'	46'	49'	52'	56'
B - Reach	21'	25'	25'	29'	33'	33'
C - Height	20'	20'	25'	25'	25'	28'
D - Distance	21'	21'	25'	25'	25'	28'

Augers at 30°	57'	61'	65'	71'	76'	82'
A - Elevation	30'	33'	36'	39'	42'	44'
B - Reach	23'	28'	28'	33'	37'	37'
C - Height	15'	15'	25'	15'	19'	21'
D - Distance	23'	23'	25'	23'	29'	34'

OPTIONS & ACCESSORIES

- 1/4" ga. flight - for 8" & 10" augers
- Discharge Spout - for 8" & 10" augers
- Overflow Spout - for 8" & 10" augers (std. on 12")
- Bucket Spout, 4 & 6 ft. lengths - for 8"/10" augers
- Metalflex Hose, 3 ft. length - for 8" & 10" augers
- Screen Tube, 4 ft. of screen on incline tube, includes cover - for 8" & 10" augers
- Low Profile Twin Screw Hopper - all augers
- Hydraulic Power Rotate Kit for Hopper
- Side Drive Kit - Positions tractor at 90° to auger for more hopper swing latitude.

Distributed By:

SUDENGA INDUSTRIES, INC.

Box 8 • 2002 Kingbird Ave. • George, IA 51237 USA
1-888-SUDENGA (783-3642) • 1-712-475-3301 • Fax: 1-712-475-3320
sales@sudenga.com • www.sudenga.com